

ROAD GRADE	RAMP LENGTH (12:1)	
	LOW SIDE	HIGH SIDE
≤ 1%	6'	6'
2%	6'	7'
3%	6'	8'
4%	6'	10'
≥ 5%	6'	13'

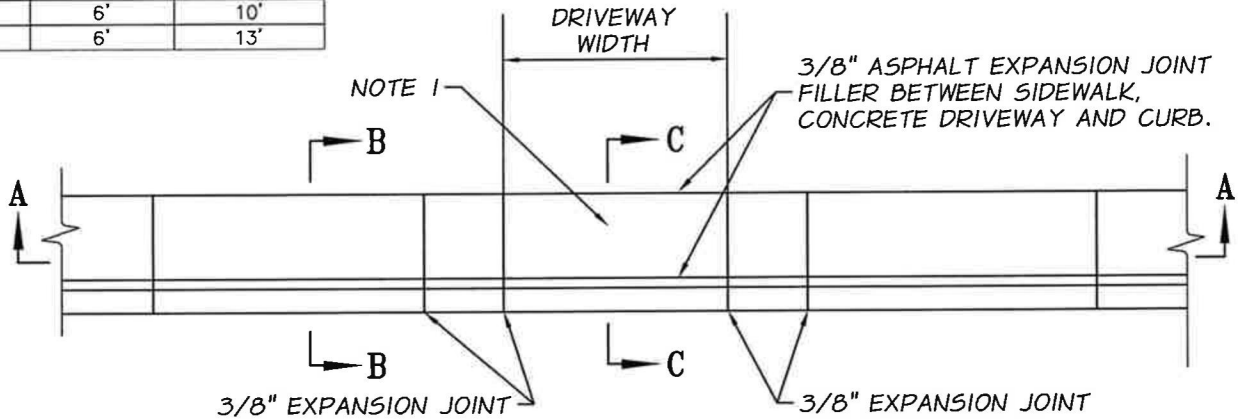

TYPICAL RESIDENTIAL DRIVEWAY ENTRANCE
NTS

NEW DRIVEWAY WIDTHS:

- 1) RESIDENTIAL DRIVEWAYS: WIDTH SEE PLANS
- 2) DEPRESSED DRIVEWAYS MUST BE SEPARATED BY AT LEAST 20.0' OF FULL HEIGHT CURB (ANY DEVIATIONS MUST BE APPROVED BY THE COUNTY ENGINEER).
- 3) FOR MOUNTABLE CURBS, SIDEWALK 0.5' MINIMUM THICKNESS.
- 4) PREMOLDED JOINT FILLER SHALL MEET THE REQUIREMENT OF SECTION 9-04.1 OF THE STANDARD SPECIFICATIONS.
- 5) FOR CEMENT CONCRETE DRIVEWAY DETAIL, SEE WSDOT STANDARD PLAN F80-10.-04, TYPE 1. WHEN THE DRIVEWAY WIDTH EXCEEDS 20' (FT), CONSTRUCT A FULL DEPTH EXPANSION JOINT WITH 3/8" (IN) JOINT FILLER ALONG THE DRIVEWAY CENTERLINE.

CEMENT CONCRETE DRIVEWAY ENTRANCE TYPE - RESIDENTIAL



APPROVED BY: [Signature] DATE: 4/26/23
County Engineer: _____

REVISION:	DESCRIPTION:	DATE:

STANDARD PLAN
S-7
SHEET 2 OF 3